

// KNPHEIDE VAN EQUIPMENT

KVE FOLD OUT SHELF INSTALLATION INSTRUCTIONS



This document must not be copied or communicated to a third party without the expressed authorization of The Knapheide Manufacturing Company.

FOR REF ONLY

Printed copies are uncontrolled.

INTRODUCTION //

The Knapheide Manufacturing Company takes pride in manufacturing only the best quality products available in the truck equipment industry today. Proper operation and maintenance of Knapheide products will assure many years of service. Thoroughly read and understand all of the information provided in this manual and all OEM manuals. Follow all manufacturer's recommendations to qualify for warranty coverage.

This manual and other information provided by The Knapheide Manufacturing Company, its subsidiaries, and authorized distributors are designed to provide system and accessory operation for examination by users with the technical expertise of the product. Users should examine their system and determine, with the help of this manual, the functionality of all included accessories. The operator, through personal analysis and testing, is solely responsible for making sure that all performance and safety requirements of the application are met.



The Knapheide Product Support Center
1848 Westphalia Strasse | P.O. Box 7140 | Quincy, IL 62305

P: 217-592-5233 |

productsupport@knapheide.com

Knapheide product warranty information

can be found at

<https://www.knapheide.com/files/source/knapheide/Service/Knapheide-Warranty.pdf>

// ASSEMBLY HARDWARE

PARTS			
Letter	Part Number	Description	Image
A	30708270	Flange Lock Nut 5/16-18	
B	12041109	Washer 0.38 x 0.88	
C	34524812	Bolt Hex 0.31-18 x 4.25	
D	31774820	Bolt Whiz UNC 0.31 X 1.0	
E	12030185	Whiz Lock Nut 0.31"	
F	12075065	Bolt Whiz UNC 0.31 X 0.75	
G	50903910	Riv-Nut 5/16-18 UNC HD Plus	
H	32394850	Bolt Whiz UNC 0.31 X 1.50	
I	31884950	Spacer Nylon 0.75OD X 0.375ID X 0.375H	

CAUTION: Use of hardware other than provided, or alternative installation methods other than outlined herein, may void the product warranty. Fasteners should be tightened to called out specification or use Fastenal website torque calculator for any hardware not called out. Use caution when using air or battery operated tools.

// MOUNTING PARTS

PARTS			
Letter	Part Number	Description	Image
J	33897087	Ecofix Bracket 265	
K	34724461* OR 34922785*	Bracket Wall Mount UFS2	
L	34724873	Mounting Foot LH UFS2	
M	34724893	Mounting Foot RH UFS2	

*NOTE: Bracket 34724461 will be used with all shelving unit kits for heights of 63” and 48”.
Bracket 34922785 will be used with all shelving unit kits for heights of 65” and 52”

CAUTION: Use of hardware other than provided, or alternative installation methods other than outlined herein, may void the product warranty. Fasteners should be tightened to called out specification or use Fastenal website torque calculator for any hardware not called out. Use caution when using air or battery operated tools.

// INSTALLATION INTRUCTIONS

WARNING!

For E-transits, review the Ford Body Builder Layout book and Body Equipment Mounting Manual for applicable no drill zones, fastener clearance information, electrical and sub-system routing information, etc. Note that care should especially be taken when drilling through the floor that proper clearance is maintained between the drill bit and the electrical components per these OEM documents.

1. Unbox all packages (2 hardware bags, 2 uprights, and 2 shelf assemblies). A large table to assemble on will be useful.
2. Set the shelf assembly on to the workspace with the top of the shelf facing down.
3. Determine and mark the shelf mounting points from the bottom-up of the upright, being sure to clear the wheel well if the shelving unit will be positioned in that area of the van.
4. Install a **C** 4" hex bolt from the top/front, with a **B** 3/8" washer in the second hole from the bottom of the shelf assembly's U channel and through the shelf unit upright, and start an **A** flange lock nut from the backside. See Figure 1 (bottom hole highlighted in image).
5. Install another **C** bolt, **B** washer, and **A** lock nut in the top hole of the U channel. The head of the bolt should be facing up in this step and towards the middle of the van in the final installation.
6. You can use a power tool/impact to run the **A** nut in close but **DO NOT** tighten with the impact. Finish tightening to 15 ft./lbs. at both locations. See Figure 2.

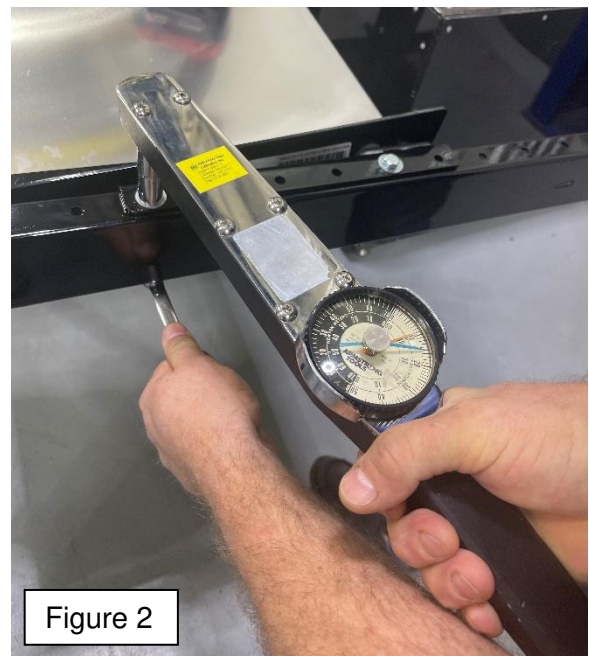

7. Position the second shelf on the workspace and repeat the above procedure (steps 3-6) with a minimum of 5 open holes between shelf assembly U channels, see Figure 3. Double-check the clearance in the van by confirming the measurements so that the shelf will clear the roof when installed and in both folded and unfolded states.

8. Add the second upright to the opposite side and install **C** bolts, **B** washers, and **A** nuts for both shelves ensuring they are mounted in the same height hole locations.

9. Take the top **K** wall mount shelf bracket and with the bracket facing outward, loosely mount it to the top of the upright using the first and third horizontal slots in the bracket and the upright, mount with the **D** serrated flange bolt and **E** serrated flange nut. Mount with the head of the bolt facing the outside with the nut on the inside. Finger tighten only. Repeat for the second upright. See Figure 4. If installing more than one shelf see step 14.



10. Loosely mount both the **L** and **M** mounting foot brackets similarly with the **D** bolt and the **E** nut at the bottom of both uprights, using the bottom and the third holes.
11. Using two people, place the assembled unit inside the van and rest the unit in the best location. Ideally, the mounting holes in the **L** and **M** feet will all locate on top of floor ribs or in areas without ribs. Both **L** and **M** mounting feet need to be at the same height. 2 **I** plastic spacers are provided for if 1 or 2 mounting locations are lower than the rest. See Figure 5.



12. Review the top **K** brackets wall locations. If needed the top **K** brackets can be adjusted down but the best practice is to keep these as high as possible, the top **K** brackets can also be flipped 180 degrees if needed to clear the van structure. See Figure 6.
13. Square the uprights vertically and ensure corner to corner dimensions are equal to make sure the unit is installed square. Finger tighten the bolts that hold the brackets to the uprights for both the **L** and **M** mounting feet and the top **K** mount brackets.

14. If installing 2 units together on the same side the two middle uprights that face each other will share the hardware for the top and bottom mounting brackets and each **D** bolt will extend through both mounting brackets and both uprights. See Figure 7. **Note:** In this scenario, the upper **K** mounting brackets will be flipped 180 degrees and will face inward towards the center of the shelving unit. Ensure the second unit is on the same centerline as the first unit.

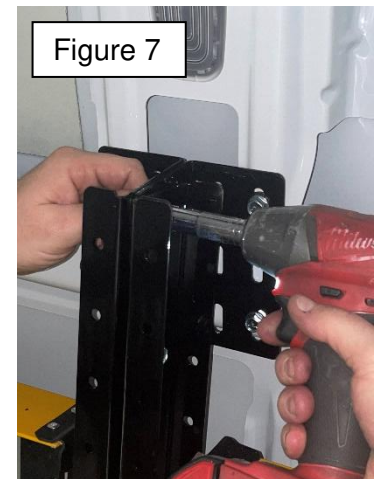

15. Mark the center of the mounting holes on the floor and inner wall structure. Verify that all mounting hole locations are clear of any obstacles such as wiring, brake or fuel lines, fuel tanks, or vertical walls of under supports.

16. Move shelving units out of the way to then drill 1/2" holes and install **G** 5/16" plus nuts into the floor and the inner wall structure of the van. See Figure 8. Plus-nuts are designed for a grip range from .020" - .280".



17. Position the shelving unit back in the proper location and install 1.5" **H** whiz bolts through the **L** and **M** mounting feet and into the **G** plus nuts in the floor, using **I** spacers where necessary. Also install .75" **F** whiz bolts through the **K** mounting brackets and into the wall, tightening all of the mounting bolts and ensure that uprights are vertical (90 degrees to the floor).

18. Take the **J** EcoFix brackets and determine mounting locations. Brackets should be attached approximately midway up the uprights and tied into the mid bracing of the van. (Figure 9). All uprights will have two **J** brackets (one facing each direction). Bend **J** brackets as needed following the following guidelines (Figure 10);

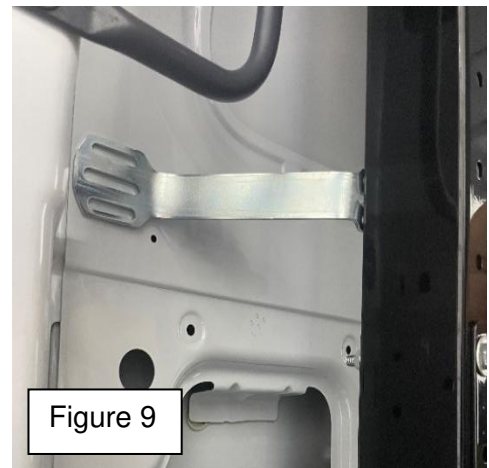
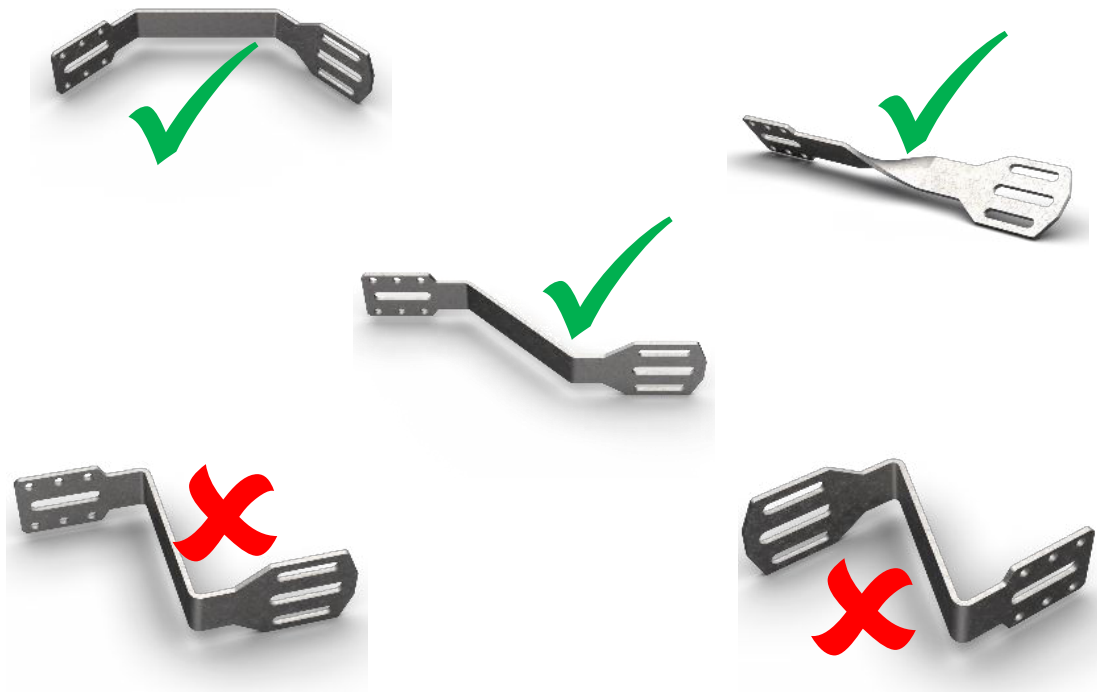

Figure 9

- a. Ecofix brackets can be bent with a bracket bending tool or by hand.
- b. Ecofix brackets can only be bent or twisted one time. **DO NOT** straighten a bent Ecofix bracket and bend it again as this will cause embrittlement!
- c. **DO NOT** bend Ecofix brackets past 60 degrees.
- d. If necessary. Eco Fix brackets can be twisted to a maximum of 90 degrees.



Figure 10



Mounting Ecofix Brackets

The recommended position for mounting Ecofix brackets is the horizontal position, as indicated by the dark bracket below.

Acceptable mounting positions, within 45° in either direction of the horizontal position, are indicated by the lighter brackets shown.

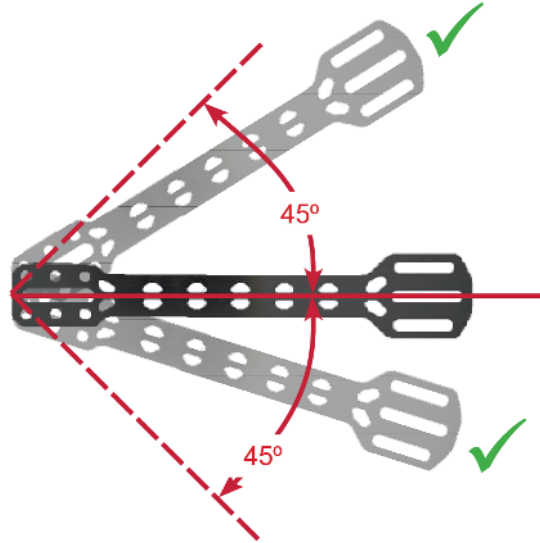

Recommended and Acceptable Mounting Positions

Unacceptable mounting positions, outside 45° in either direction of the horizontal position, are indicated by the lighter brackets shown.

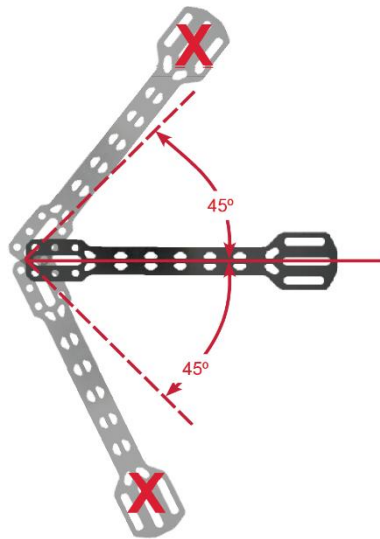

Unacceptable Mounting Positions

19. Bolt the **J** brackets through the back of the upright using **D** bolts and **E** nuts (Figure 11). At each upright, both **J** bracket will share one **D** bolt into the shelf upright. Finger tight the hardware in the **J** Bracket to hold the bracket in the upright position and then mark the wall for the locations to install the **G** plus nuts.

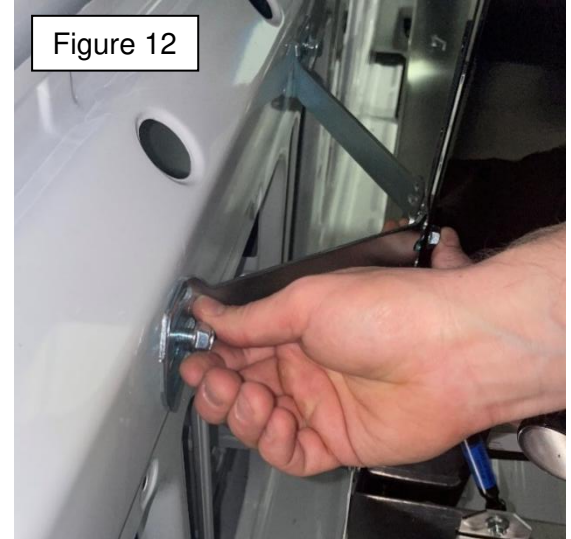

20. After marking, swing the **J** brackets out of the way, then drill and install **G** plus nuts. Swing **J** brackets back in place, and proceed to mount **F** bolts into the wall and then tighten both wall and upright hardware. See Figure 12.
21. Confirm that the unit is level and square with the floor. Tighten bolts mounting the unit to the wall and hardware mounting top brackets and feet to the unit. **DO NOT** tighten hardware mounting shelf units to the U uprights beyond the 15 ft.-lbs. called out in Step 6.
22. Repeat for additional van shelving units and follow the same process.



The Knapheide Product Support Center
1848 Westphalia Strasse | P.O. Box 7140 |
Quincy, IL 62305

P: 217-592-5233 |
productsupport@knapheide.com